

Standard cyclone filter, extra-large kombi cooler (oil and water), the Kubota diesel engine meets the latest emission regulations.

GIANT wheel loader with ROPS bar, ROPS/FOPS safety roof or with ROPS/FOPS cabin with preparation for several options.

Low drivers platform for driving through small heights, mounted on low noise blocks. Great view due the Z-kinematic. The low centre of gravity grants a good stability.

Integrated counterweight prepared for traffic lights. Cleves integrated. 2 hydraulic oil tanks with a vast volume.

Several tyres and wheels available with different sizes and profiles. Planetary end-drive with 100% electric switchable differential lock on both axles.

Comfortable suspension seat with armrests and headrest. Driving platform on rubber suspension silent blocks.

Lifting arm with a double Z-kinematic, for perfect parallel movement. And an higher tiltforce. Optimal view at your work.

Width range of attachments designed and produced by TOBROCO.

Hydraulic quick-fit system GIANT linkage. standard 3e hydraulic funktion, Euro linkage is optional.



## WHEEL LOADERS

GIANT wheel loaders are totally designed and produced in own management in Oisterwijk (the Netherlands). In 2009 TOBROCO Machines has started with the development for new models for the existing range. These new models will replace the existing ones. For development TOBROCO Machines is using a sophisticated 3-dimensional design program. Thus before taken a machine in production, it's performance can be tested already. During the development of the new models TOBROCO takes care of the demands and needs of their customers. TOBROCO is a specialist in compact wheel loaders.

In the modern plant in Holland they build the GIANT wheel loaders. We work with the best suppliers: Kubota, Rexroth. GIANT is robust, durable and quality made in Holland! Also TOBROCO Machines offers you a very big variety of implements. The majority of these implements is designed and produced by TOBROCO Machines, and because of this, the implements are optimally adapted for your GIANT, which is more efficient this way.



### TOBROCO

Industrielaan 2  
5061 KC Oisterwijk  
Tel.: +31 (0)13-5211212  
Fax: +31 (0)13-5234045  
Internet: www.tobroco.com  
E-Mail: info@tobroco.com



# GIANT

**Team TOBROCO**  
Industrielaan 2, 5061 KC Oisterwijk  
Tel.: +31 (0)13-5211212  
Fax: +31 (0)13-5234045  
Internet: www.tobroco.com  
E-Mail: info@tobroco.com

V4502T  
V4502T X-TRA  
V5003  
V5003 X-TRA  
V5003T  
V5003T X-TRA  
V6004T  
V6004T X-TRA



## WHEEL LOADERS

Flexible, strong and comfortable jack of all trades



All technical data in this brochure refer to series models that have been tested under operating conditions typical of Central Europe and describe their standard functions. Specifications and their modes of functionality as well as accessories listed in this brochure depend on the individual model and on the options available with a particular product as well as the statutory requirements of the country of sale. Illustrations used in this brochure may show products that have not been mentioned or that are not available as series production machines. The descriptions, illustrations, weights and technical data published herein are non-binding in nature and represent the technical status at the time the document went to press. Because of ongoing development, we reserve the right to make changes, without prior notice, to the design, specification, visual appearance and technology of our products. Should you require special functions that would be available only by using additional components and/or under special circumstances, please feel free to contact us. We will be happy to answer any questions you may have and to provide further information regarding whether and under what conditions applying to the product and the target environment such special functions might be feasible. If you have any concerns about the load capacity or operation of our products in certain working conditions or environments, we recommend that you perform a test run under controlled conditions. Despite meticulous attention to detail, we cannot exclude the possibility that our products may not conform to illustrations or stated dimensions, or that errors may have occurred in calculation or during printing, or that the information given here may be incomplete. Consequently, we do not accept liability for the accuracy or completeness of the information supplied in this brochure. All matters relating to our product warranty are contained within our General Terms and Conditions. We expressly decline to provide additional guarantees. Any liability over and above that contained within our General Terms and Conditions is excluded.



# WHEEL LOADERS

To fulfill the needs and demands of her customers TOBROCO offers a wide range of wheel loaders. This range consists out of different types of loaders with a service weight between 1000 kg and 4150 kg. In this leaflet, we will show you the range of GIANT's with a service weight of 3100 kg to 3400 kg. In this leaflet you find the machines in the heavy comfort range. For further information about other types and implements we refer to our other leaflets or our website ([www.tobroco.com](http://www.tobroco.com)).



## ● V4502T X-TRA / V5003T X-TRA

The GIANT X-TRA range is based on the normal range. The lower front frame gives these GIANT's have a higher tipping load. And because of their lower centre of gravity our loaders are secure and have an good stability even under difficult conditions. The X-TRA models are often used in earthworks and road construction. The X-TRA models dont have Z-kinematic.

## ● V4502T / V5003T

The GIANT V4502T and the GIANT V5003T replaces the successful range V4501T - V5002T GIANT Wheel loaders. The new models have a new design, cyclone filter, main switch electro., ROPS/FOPS safetyroof, luxury seat, standard 1 counterweight integrated in the backside. Heavy planetary end drive axles with electric 100% differential lock on both 12 tons axles. The machine has an hydraulic quick change. with 3e hydraulic function. Also an robust Z-kinematic on the lifting arm. The kinematic system has been designed in such a way to facilitate the quick loading and unloading of your cargo. There is a better visibility on the working tools with Z kinematic.

# TECHNICAL DATA



## ● V6004T & V6004T X-TRA

The GIANT V6004T, 60 hp Kubota turbo engine, 14 tons heavy planetary end drive axles with electric 100% differential-lock, top speed 28 km/h. and is the strongest machine of the range. The V6004T has an Z-kinematic lifting arm, lifting height 329 cm. The kinematic system has been designed in such a way to facilitate the quick loading and unloading of your cargo. There is a better visibility on the working tools with Z kinematic. The X-TRA has a lower front frame these GIANT's have a higher tipping load. And because of their lower centre of gravity our loaders are secure and have a good stability even under difficult conditions.

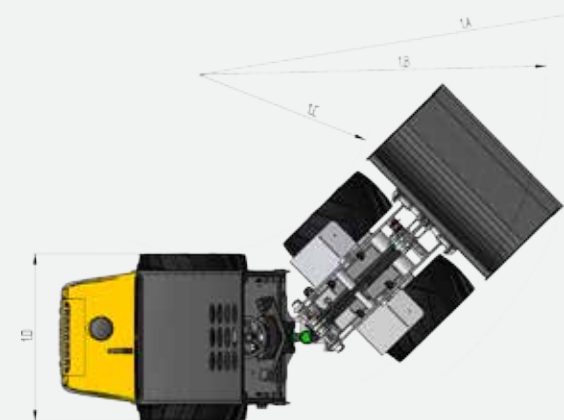

	V4502T	V4502T X-TRA	V5003	V5003 X-TRA	V5003T	V5003T X-TRA	V6004T	V6004T X-TRA
Engine	4 cyl. Kubota turbo 45 hp / 33 kW	4 cyl. Kubota turbo 45 hp / 33 kW	4 cyl. Kubota 50 hp / 36 kW	4 cyl. Kubota 50 hp / 36 kW	4 cyl. Kubota 60 hp / 44 kW	4 cyl. Kubota 60 hp / 44 kW	4 cyl. Kubota turbo 60 hp / 44 kW	4 cyl. Kubota turbo 60 hp / 44 kW
Service weight	3200 kg	3100 kg	3300 kg	3100 kg	3300 kg	3100 kg	3400 kg	3300 kg
Driving hydraulics	Hydrostatic automotive	Hydrostatic automotive	Hydrostatic automotive	Hydrostatic automotive	Hydrostatic automotive	Hydrostatic automotive	Hydrostatic automotive	Hydrostatic automotive
Driving speed	0-8 km/h 0-25 km/h	0-10 km/h 0-25 km/h	0-10 km/h 0-25 km/h	0-10 km/h 0-25 km/h	0-10 km/h 0-25 km/h	0-10 km/h 0-25 km/h	0-10 km/h 0-25 km/h	0-10 km/h 0-25 km/h
Driving mech.	Planetary end drive	Planetary end drive	Planetary end drive	Planetary end drive	Planetary end drive	Planetary end drive	HD Planetary end drive	HD Planetary end drive
Differential lock	Electr. 100% on both axles	Electr. 100% on both axles	Electr. 100% on both axles	Electr. 100% on both axles	Electr. 100% on both axles	Electr. 100% on both axles	Electr. 100% on both axles	Electr. 100% on both axles
Standard tyres	11.5/80-15.3 AS	11.5/80-15.3 AS	11.5/80-15.3 AS	11.5/80-15.3 AS	11.5/80-15.3 AS	11.5/80-15.3 AS	12.0/75-18 TR11 AS	12.0/75-18 TR11 AS
Service brake	Hydraulic	Hydraulic	Hydraulic	Hydraulic	Hydraulic	Hydraulic	Hydraulic	Hydraulic
Parking brake	drumbrake	drumbrake	drumbrake	drumbrake	drumbrake	drumbrake	drumbrake	drumbrake
Quick linkage	GIANT Standard Hydraulic	GIANT Standard Hydraulic	GIANT Standard Hydraulic	GIANT Standard Hydraulic	GIANT Standard Hydraulic	GIANT Standard Hydraulic	GIANT Standard Hydraulic	GIANT Standard Hydraulic
Driving hydraulics	84 L/min (440 bar)	84 L/min (440 bar)	84 L/min (440 bar)	84 L/min (440 bar)	84 L/min (440 bar)	84 L/min (440 bar)	126 L/min (350 bar)	126 L/min (350 bar)
Working hydraulics	53 L/min (190 bar)	53 L/min (190 bar)	53 L/min (190 bar)	53 L/min (190 bar)	53 L/min (190 bar)	53 L/min (190 bar)	53 L/min (190 bar)	53 L/min (190 bar)
Lifting capacity	2460 kg	2880 kg	2480 kg	2900 kg	2480 kg	2900 kg	2500 kg	2920 kg
Tipping load straight	2000 kg	3480 kg	2030 kg	3550 kg	2030 kg	3550 kg	2200 kg	3800 kg

	V4502T	V4502T X-TRA	V5003	V5003 X-TRA	V5003T	V5003T X-TRA	V6004T	V6004T X-TRA
A Wheel base	1831	1880	1831	1880	1831	1880	1831	1880
B Total lenght without bucket	3790	3705	3790	3705	3790	3705	3790	3705
C Total lenght with bucket	4525	4475	4525	4475	4525	4475	4525	4475
D Lenght 3-point lifting arm (option)	540	540	540	540	540	540	540	540
E Min height 3 point hitch	253	253	253	253	253	253	253	253
F Max. height 3 point hitch	652	652	652	652	652	652	652	652
G Seat height	1300	1300	1300	1300	1300	1300	1345	1345
H Max. height with ROPS/FOPS safetyroof	2263	2263	2263	2263	2263	2263	2310	2310
I Max. height with cabine	2255	2255	2255	2255	2255	2255	2300	2300
J Height frontframe	1711	1640	1711	1640	1711	1640	1711	1685
K Max. bucket pin height	2449	1800	2449	1800	2449	1800	2494	1845
L Max. dump height	3247	2658	3247	2658	3247	2658	3292	2703
M Height with bucket	3753	3244	3753	3244	3753	3244	3798	3244
N Roll back angle ground level	41°	41°	41°	41°	41°	41°	41°	41°
O Roll back angle	57°	44°	57°	44°	57°	44°	57°	44°
P Max. dump angle	43°	47°	43°	47°	43°	47°	43°	47°
Q Max. drive angle	28°	28°	28°	28°	28°	28°	30°	30°
R Diameter standard tyre	Ø850	Ø850	Ø850	Ø850	Ø850	Ø850	Ø940	Ø940
1A Maximum radius	3281	3281	3281	3281	3281	3281	3281	3281
1B Outer turning radius	2859	2859	2859	2859	2859	2859	2859	2859
1C Inner turning radius	1476	1476	1476	1476	1476	1476	1476	1476
1D Width	1340	1340	1340	1340	1340	1340	1400	1400

Sizes in mm.

	V4502T	V4502T X-TRA	V5003	V5003 X-TRA	V5003T	V5003T X-TRA	V6004T	V6004T X-TRA
S	2000 kg	3530 kg	2030 kg	3550 kg	2030 kg	3550 kg	2200 kg	3800 kg
T	1950 kg	2700 kg	1980 kg	2720 kg	1980 kg	2720 kg	2250 kg	2850 kg
U	1450 kg	1990 kg	1470 kg	2010 kg	1470 kg	2010 kg	1685 kg	2200 kg
V	1150 kg	1450 kg	1170 kg	1470 kg	1170 kg	1470 kg	1375 kg	1575 kg
W	2700 kg	3800 kg	2720 kg	3820 kg	2720 kg	3820 kg	3150 kg	4100 kg
X	1920 kg	2450 kg	1950 kg	2460 kg	1950 kg	2460 kg	2275 kg	2650 kg
Y	1450 kg	1640 kg	1470 kg	1660 kg	1470 kg	1660 kg	1800 kg	1880 kg

Tipping load in straight position, without extra counterweights.